



# BUILDING A BETTER I-4

## Stay Informed:

- » Project Hotline: 844-ULT-INFO (858-4636)
- » Sign up for email and text alerts at [fdot.tips/alerts](https://fdot.tips/alerts)
- » Subscribe to our monthly newsletter at [fdot.tips/news](https://fdot.tips/news)
- » Follow us on Twitter at [fdot.tips/twitter](https://fdot.tips/twitter)
- » Subscribe to our YouTube channel at [fdot.tips/youtube](https://fdot.tips/youtube)

## E.E. WILLIAMSON ROAD BRIDGE REPLACEMENT

The widening of I-4 — both for this project and the final I-4 Beyond the Ultimate configuration — requires FDOT to rebuild the E.E. Williamson Road overpass. The overpass will be constructed in phases to maintain both eastbound and westbound access. (See reverse side for phases of construction.)

- » The bridge will be widened to include a 6-foot-wide sidewalk on the eastbound side of E.E. Williamson Road and a 10-foot-wide trail on the westbound side.
- » Both directions of E.E. Williamson Road will include 6-foot, 4-inch bike lanes.
- » Construction began in September 2019.
- » During construction, lane closures on E.E. Williamson Road will occur overnight between 8 p.m. and 6:30 a.m.
- » During overnight lane closures, flaggers will be present along E.E. Williamson Road to allow both directions of traffic to alternate use of the open lane.

## CROSS SECTION OF THE NEW E.E. WILLIAMSON ROAD BRIDGE OVER INTERSTATE 4 (I-4)

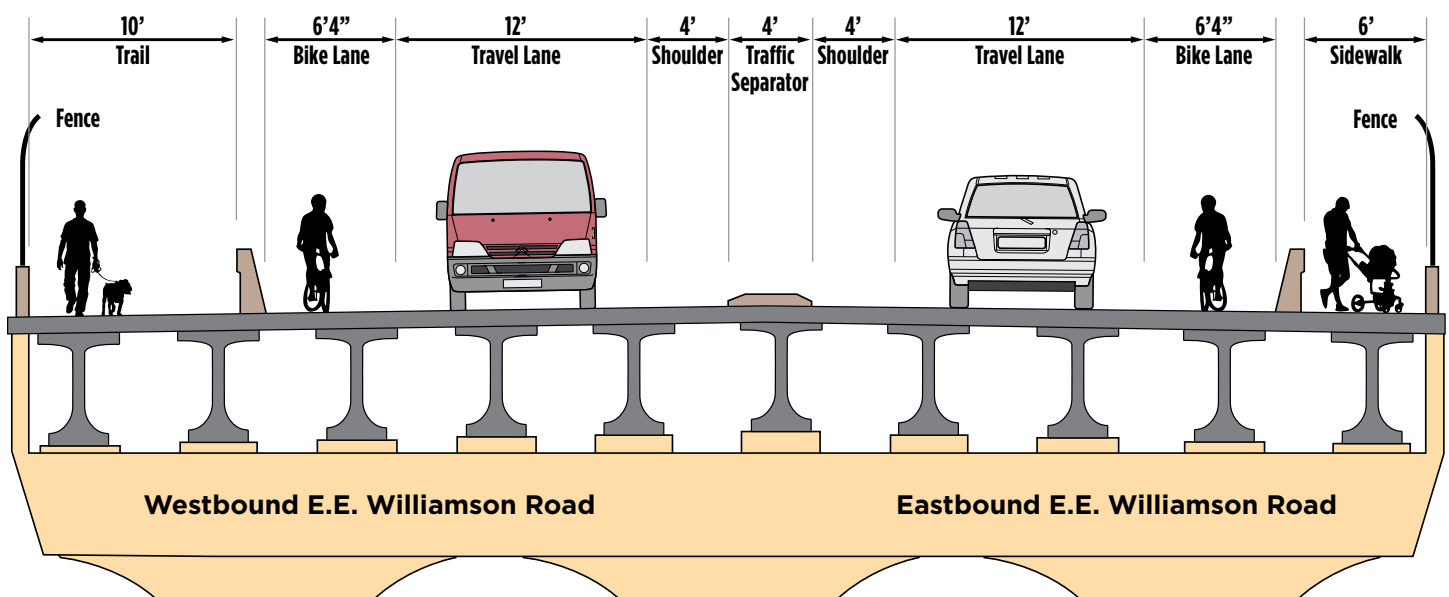

Schedule subject to change. Construction progress, roadway conditions and weather may require schedule adjustments. Please check [i4beyond.com/alertsmap](https://i4beyond.com/alertsmap) for the most up-to-date information.



Sign up for I-4 Construction Updates and Alerts at [I4Beyond.com](https://I4Beyond.com)  
Learn about commuter options in Central Florida at [reThinkYourCommute.com](https://reThinkYourCommute.com)





# BUILDING A BETTER I-4

## Stay Informed:

- » Project Hotline: 844-ULT-INFO (858-4636)
- » Sign up for email and text alerts at [fdot.tips/alerts](mailto:fdot.tips/alerts)
- » Subscribe to our monthly newsletter at [fdot.tips/news](mailto:fdot.tips/news)
- » Follow us on Twitter at [fdot.tips/twitter](https://twitter.com/fdot.tips/twitter)
- » Subscribe to our YouTube channel at [fdot.tips/youtube](https://www.youtube.com/fdot.tips/youtube)

## E.E. WILLIAMSON BRIDGE INTERIM PHASES

The widening of Interstate 4 (I-4) for the additional eastbound I-4 auxiliary lane currently under construction and the future I-4 Beyond the Ultimate final configuration requires the E.E. Williamson Road overpass to be reconstructed.

Construction of the overpass began in September 2019 and is anticipated to be completed by Spring 2021. During construction, the new bridge will be built in phases to maintain both eastbound and westbound access. See below for more information about the upcoming traffic phases on the E.E. Williamson Road overpass:

### Phase 1

E.E. Williamson Road over I-4 will remain mostly unchanged for motorists while crews work on constructing a portion of the new bridge on the south side.

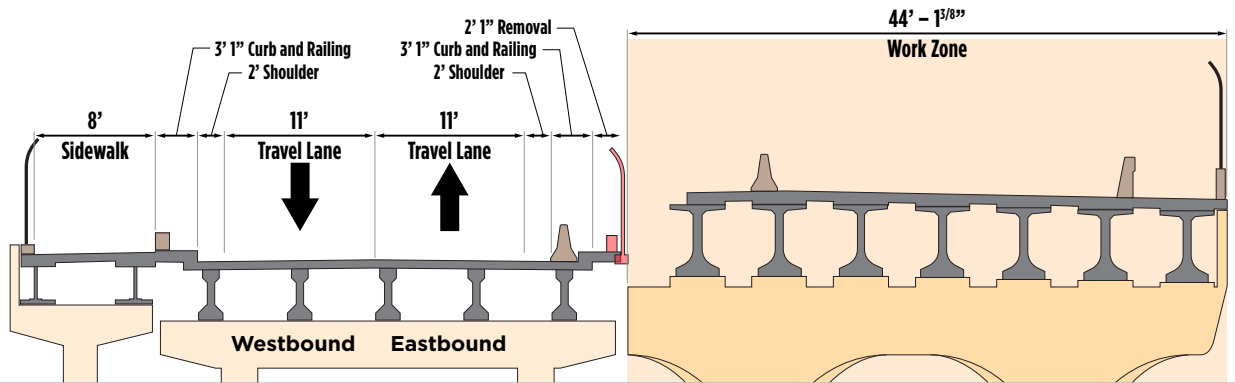

### Phase 2 (Stage 1)

Vehicular and pedestrian traffic will be shifted from existing bridges to the newly constructed bridge portion and the existing bridge will be demolished.

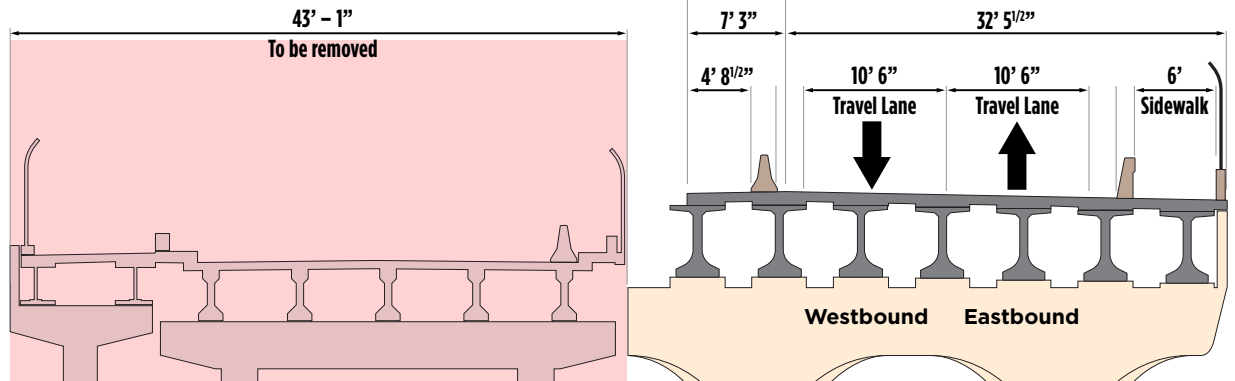

### Phase 2 (Stage 2)

Vehicular and pedestrian traffic will be maintained on portion of the new bridge as crews work behind barrier wall to construct the final portion of the new bridge.

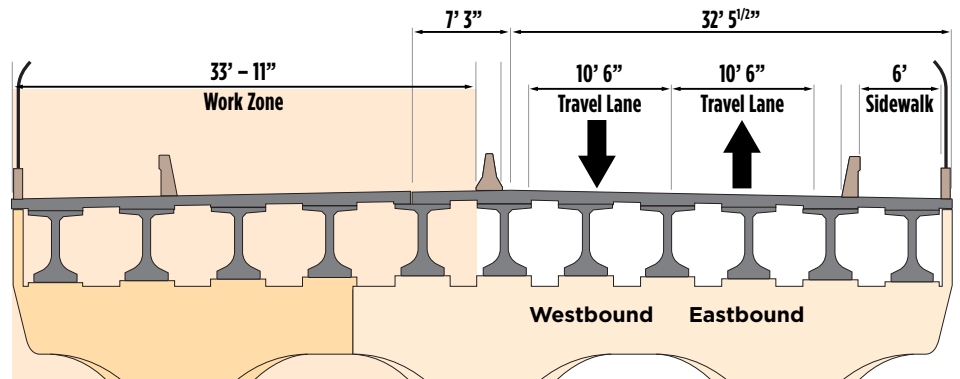

Persons with disabilities who require accommodations under the Americans with Disabilities Act or persons who require translation services (free of charge) should contact David Parks, Community Outreach Specialist, by phone at 844-858-4636, or via email at [DavidParks@i4ultimate.com](mailto:DavidParks@i4ultimate.com). If you are hearing or speech impaired, please contact us by using the Florida Relay Service, 1-800-955-8771 (TDD) or 1-800-955-8770 (Voice).

Public participation is solicited without regard to race, color, national origin, age, sex, religion, disability or family status. Persons wishing to express their concerns relative to FDOT compliance with Title VI may do so by contacting Jennifer Smith, FDOT District Five Title VI Coordinator at [Jennifer.Smith2@dot.state.fl.us](mailto:Jennifer.Smith2@dot.state.fl.us).

